



MICROLINE 320 FB



MICROLINE 320 FB

9 Pin Dot-Matrix Printer



**Professional
printers you
can rely on**

OKI
People to People Technology

MICROLINE 320 FB

MICROLINE

MICROLINE 320 FB

TECHNICAL FEATURES



Major Applications

Its elegant styling and straight paper path make the ML 320FB ideal for professional business applications and service industries – but it is also suited to industrial applications where users need fast printing on multi-part forms or non-standard sized paper. Easy setting for cut sheets, auto-feeding and auto-parking significantly improve performance and productivity over alternative dot-matrix solutions.

- General business use – multi-part forms, labels, envelopes, thicker paper stocks
- Reception areas – menu cards, registration cards, hire forms etc.
- Administration – letters/reports and other internal documents

General Printer Characteristics

- Number of pins: 9
- No. of multi-part forms: 5 (one original + 4 copies)
- Print speed at:
 - High speed draft: 360 cps 300 cps
 - Utility: 250 cps 250 cps
 - NLQ: 62.5 cps 62.5 cps
- Fastest print speed: 360 cps
- Carriage width (10 cpi): 106 columns
Max. in compressed mode: 212 columns
- Dimensions:
 - Height: 200 mm
 - Width: 465 mm
 - Depth: 343 mm
 - Weight: 12 kg
- Continuous paper: 3-12" (76-305 mm)
- Card stock weight: 12-50 lbs 45-189 g/m²
- First printable line: 0.02" (0.5 mm)
- Character pitch: 5 to 20 pitch & proportional
- Graphics resolution: Up to 240 x 216 dpi
- Memory: Standard buffer 28 Kbytes (reduced buffer)
- Noise level: 58 dBA
- Power requirements: 230V AC (+6%, -14%) 240V AC (±10%)
- Frequency: 50/60 Hz

Interfaces & Emulations

- Emulations: Epson FX, IBM Proprinter
- Standard interface: Centronics Parallel
- Optional interfaces: Serial RS 232C/RS 422/Current Loop

Reliability

- Print head life: 200 million characters
- Ribbon life: 2 million characters
- MTBF: 5,000 hours



Paper Handling

Standard

- Paper parking
- Autoload single sheet
- Push tractors

Optional

- Single bin sheet feeder

Font & Print Features

- Resident typefaces (4): Courier, Sans Serif, Utility, HSD
- Font styles: Italics

1. Front feed tractor: For continuous forms and listing paper
2. Front feed manual: Horizontal insertion for a variety of stationery – front eject for convenience
3. Top feed automatic: For cut-sheet feeder applications – invoice sets, card stock, envelopes, etc.

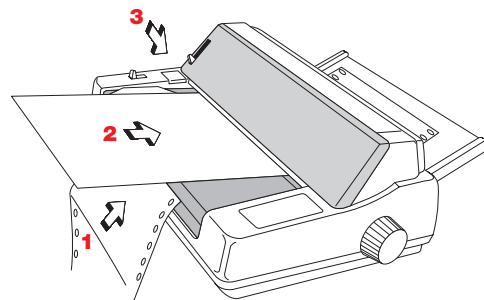

European Head Office Okidata Europe Limited

Central House
Balfour Road
Hounslow
Middlesex
TW3 1HY
United Kingdom

Okidata strongly recommends the use of original Okidata ribbons. Inferior ribbons are less durable and can damage your print head.

Specifications subject to change without notice.

All trademarks acknowledged.

As an ENERGY STAR partner, Okidata has determined that this product meets the ENERGY STAR guidelines for energy efficiency

Telephone +44 (0)20-8219 2190

Fax +44 (0)20-8219 2199

Web Site www.okieurope.com

OKI

People to People Technology