

# Lexmark X925de colour MFP



## Increase productivity through affordable A3 colour

### Model



#### Lexmark X925de

The Lexmark X925de colour MFP delivers affordable A3 and colour functionality for your busy workgroup through easy-to-use features, productivity solutions and a compact design.



Colour



Touch screen



Copy



Scan



Fax



Solutions



A3



Up to 31 ppm



Duplex



Network

**LEXMARK**  
TM

# Lexmark X925de: key features



## Features that help you optimise your work



### 1) Intuitive colour touch screen

The extra large 10.2-inch (25.9 cm) colour touch screen allows you to operate your printer with ease and confidence through smart and intuitive navigation, easy access to workflow solutions and shortcuts, and the ability to preview your documents and print jobs at the device.



### 2) Recirculating automatic document feeder (RADF)

Save time by scanning both sides of your document with robust colour-scanning capabilities and an input capacity of up to 100 pages.



### 3) Direct USB

The front USB port allows for convenient walk-up preview, printing and scanning, and is compatible with most printable image file formats.



### 4) Load multiple media types

150-sheet and 250-sheet input trays and a multipurpose feeder come standard, allowing you to load three media types.



### 5) Lexmark solutions

Reduce unnecessary printing and simplify work processes through solution applications preloaded on your device. Choose additional Lexmark solutions to fit your unique workflow needs.



### 6) Eco-friendly features

Print responsibly with easy-to-access features, including Eco-Mode to reduce paper and toner consumption, and the Sleep Button to help you save energy.



### 7) Front-loading toner cartridges

Cartridges are conveniently located at the front of the device for easy access.

# Lexmark X925de: overview



## Affordable A3 Colour

The Lexmark X925de delivers high quality A3 (11x17) colour multifunction performance in an affordable, compact design. Enjoy the benefits of vibrant, professional-quality output on a wide variety of media, allowing you to do more colour printing in-house.

- PANTONE® calibration for consistent colour tones
- Named Color Replacement for easy colour matching
- Supports media up to 11.7 x 48 inches (297 x 1219 mm)
- Lexmark Color Care Technology to manage colour usage and control costs



## Easy and Intuitive

The Lexmark X925de is designed for easy operation and maintenance.

- Extra large, easy to navigate 10.2-inch colour touch screen provides audible and tactile feedback to make completing tasks intuitive
- Print and scan preview features help you select documents or specific pages within a document
- Ability to change settings, such as duplex, at the device
- Robust connectivity makes it easy to integrate into almost any network environment
- Sleep Button and Hibernate Mode to reduce energy costs
- Device management software available



## Business Productivity

The Lexmark X925de combines high-performance printing, copying, scanning and faxing with time-saving solution applications designed to boost your productivity.

- Print and scan speeds as fast as 30 ppm in both black and colour
- Advanced copy functions let you interrupt long print runs to make a quick copy, and proof the first copy set before completing your copy job
- Scan to multiple destinations, including scan to email, scan to FTP, scan to fax, scan to network, and more
- Preloaded applications to drive greater efficiency, and Lexmark Embedded Solutions Framework to further extend the capabilities of the device

## Print Less. Save More.

Print less? This may seem like a surprising message for a company dedicated solely to printing. But when you consider that businesses spend, on average, up to 6% of their turnover on printing, and that active print management can cut office print costs by up to 30%\*, it makes a lot of sense. Lexmark products, solutions and services provide innovative ways to save you time, drive down costs and reduce your impact on the environment. We are committed to helping you print less and save more.



### Solutions

## Save time and money through solutions

Reduce unnecessary printing and simplify work processes with Lexmark solutions. The X925de features Lexmark Embedded Solutions Framework (eSF), our platform that enables you to add a wide range of software applications directly onto the device. Solutions are designed with your productivity in mind, helping you streamline—or even eliminate—paper intensive business processes.

### The following are solutions that come preloaded on the X925de:

### The following are a few of the Lexmark solutions available through authorised partners or Lexmark Professional Services:



#### Forms and Favourites

Eliminate waste and inefficiencies associated with preprinted forms. Store frequently printed forms, marketing materials or other documents online, then print them on demand.



#### Scan to Network

Scan a hardcopy document and route the image to one of 30 predefined personal or public shared network folders.



#### Change Language\*\*

Easily switch the language displayed on the touch screen – 18 languages supported.



#### Showroom

Display a customisable, scrolling slideshow on the colour touch screen to promote your business or products, or to communicate important messages to your customers or employees.



#### Card Copy\*\*

Save time and effort in copying identification cards, licenses and insurance cards by automatically scanning, enlarging and printing both sides of a two-sided card onto one side of a sheet of paper.



#### Background and Idle Screen

Change the touch screen background to your corporate logo, a unique message or select one of four available screens.

\* Source: InfoTrends/CapVentures., «Network Document Solutions Forecast 2007-2012, Network Document Solutions Consulting Service», August, 2008

\*\* Option to Change Language during installation

## Lexmark X925de: highlights

### Make a lasting impression with award-winning colour

The documents you print define an important image – yours. That's why Lexmark's colour MFPs help businesses be more productive and stand out with vibrant colour. With the ability to print professional quality colour in-house, you can add instant impact and save costs by virtually eliminating the need to outsource print jobs. Lexmark also offers a host of colour-access and control tools to manage costs.



#### Functions



### The right touch

The Lexmark e-Task colour touch screen is a key access point to your printer. The extra large customisable 10.2-inch interface gives you the ability to preview thumbnails of documents prior to printing, as well as change print jobs at the device. You can even view, select and print specific pages within a document directly from the touch screen. Its easy-to-use, intuitive navigation provides fast access to the functions, shortcuts and workflows you use most, and through the MyMFP feature, you can tailor your device with personal settings. New interactive sensory features provide both tactile and audible feedback, helping to guide you through each operation, confirming a touch has registered and indicating an action is transpiring.



### Protecting your information

From the data traveling through your network to the pages being printed, Lexmark's innovative security controls give you peace of mind that your valuable corporate data is protected at every stage.

- Cutting-edge user authentication and authorisation controls, including LDAP, to help protect your device and data
- Card reader option to add an extra layer of security
- Hard disk encryption, protecting sensitive data on the disk drive
- Automatic, scheduled or manual disk wiping
- IPSec, SNMPv3 and 802.1x network security supported
- Security-audit logging to help track and identify security risks



### True Image Always

Lexmark is dedicated to designing and manufacturing products that deliver exceptional quality and reliable performance. Maximise the return on your investment, extend the service life of your Lexmark printing equipment, and make a lasting impression by always insisting on Lexmark Genuine Supplies, Service and Parts. The Lexmark X925de colour printer is backed by a one-year base guarantee. For further protection against unexpected expenses or downtime, extended guarantee offerings are available.

# Lexmark X925de: ordering information

## Lexmark X925de

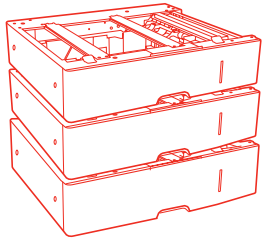
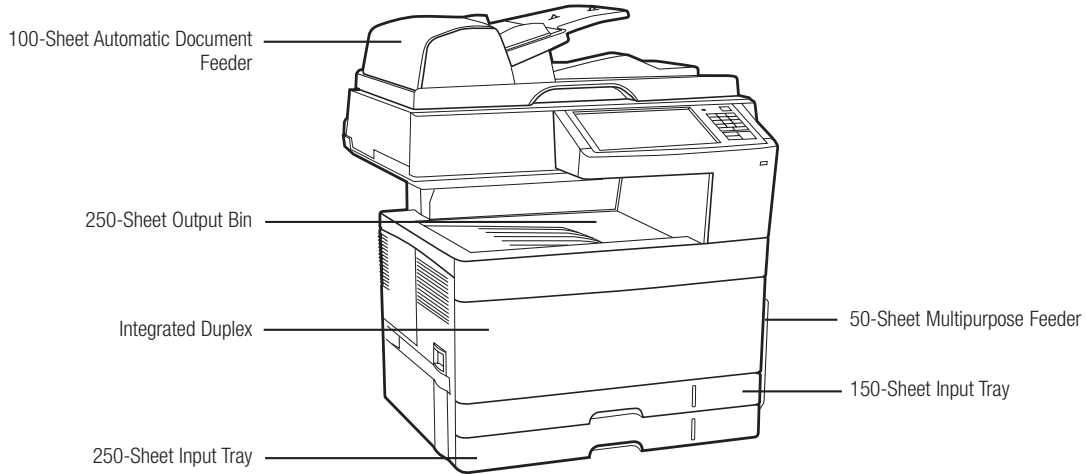

550-Sheet Drawer

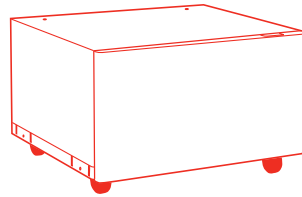

Cabinet with casters + (Use only one 550-Sheet Drawer)

■ Standard  
■ Optional



### Eco-responsible printing

Printing responsibly means everyone wins – your business, your budget and the environment. Lexmark's award-winning products are designed for ease of use, high quality output and reliable performance, with innovative capabilities that help you minimize the number of cartridges you use over the life of the printer and conserve paper and energy. Our goal is to design, package and deliver innovative products and solutions in an environmentally responsible manner.

# Lexmark X925de: ordering information

## Lexmark X925de

Part #	Model
24Z0361	Lexmark X925de
Part #	Laser Toner/Print Cartridge
X925H2KG	X925 Black High Yield Toner Cartridge (8.5K)
X925H2CG	X925 Cyan High Yield Toner Cartridge (7.5K)
X925H2MG	X925 Magenta High Yield Toner Cartridge (7.5K)
X925H2YG	X925 Yellow High Yield Toner Cartridge (7.5K)
C925X72G	C925, X925 Black Imaging Unit (30K)
C925X73G	C925, X925 Cyan Imaging Unit (30K)
C925X74G	C925, X925 Magenta Imaging Unit (30K)
C925X75G	C925, X925 Yellow Imaging Unit (30K)
C925X76G	C925, X925 Waste Toner Bottle
Part #	Paper Handling
24Z0030	C925, X925 550-Sheet Drawer
Part #	Furniture
24Z0031	C925, X925 Cabinet with casters
Part #	Memory Options
14F0245	256MB Flash Card
Part #	Application Solutions
24Z0043	X925 Card for PRESCRIBE Emulation
24Z0041	X925 Forms and Bar Code Card
24Z0042	X925 Card for IPDS
57X9000	Lexmark PrintCrypton Card
Part #	Connectivity
27X0030	MarkNet N8250 802.11b/g/n Wireless Print Server
14F0037	MarkNet N8120 Gigabit Ethernet Print Server
14F0042	MarkNet N8130 Fiber Ethernet 100BaseFX, 10BaseFL Print Server
14T0220	MarkNet N7020e Gigabit Ethernet Print Server
1021294	USB (2 Meter) Cable
14F0000	Parallel 1284-B Interface Card
1021231	Parallel (10') Cable
14F0100	RS-232C Serial Interface Card
Part #	Extended Warranties
2353820P	X925 2-Years Total (1+1) Onsite Service
2353821P	X925 3-Years Total (1+2) Onsite Service
2353822P	X925 4-Years Total (1+3) Onsite Service
2353824P	X925 1-Year Onsite Service Renewal

Part #	User Replaceable Parts
40X6093	C925, X925 Fuser Maintenance Kit 220-240V
40X6011	C925, X925 Transfer Belt and Roll
40X6328	X925 ADF Maintenance Kit
40X6432	X925 Flatbed Cushion
40X6327	X925 ADF Pick Arm
Part #	NC
2353827	X925 Installation Service

### In the box

Lexmark X925de colour multifunction printer, Up to 7,500\*-page colour (CMY) toner cartridges, Up to 8,500\*-page black toner cartridge, Black, cyan, magenta, and yellow Imaging units, Software and Documentation CD, Power Cord(s), RJ-11 Phone cable or adapter (country dependent), Setup Guides (network and local attachment), Statement of limited warranty, Lexmark Cartridge Collection Program information

# Lexmark X925de: product specifications

## Lexmark X925de

Printing	
Print Technology	Colour LED
Print Speed (A4, mono): Up to	31 ppm
Print Speed (A4, colour): Up to	31 ppm
Time to First Page (Black)	As fast as 9 seconds
Time to First Page (Colour)	as fast as 11 seconds
Print Resolution, Black	1200 Image Quality, 600 x 600 dpi
Print Resolution, Colour	1200 Image Quality, 600 x 600 dpi
Memory, standard	1536 MB
Memory, maximum	1536 MB
Hard Disk	as standard
Print Noise Level, Operating	53 dBA
Noise Level, Idle	39 dBA
Maximum Monthly Duty Cycle: Up to	200000 pages per month
Recommended Monthly Page Volume	5000 - 10000 Pages
Supplies	
Supplies Yield	Average continuous black or continuous composite CMY declared cartridge yield up to this number of standard pages in accordance with ISO/IEC 19798., 7,500*-page Colour (CMY) High Yield Toner Cartridges, 8,500*-page Black High Yield Toner Cartridge
Copying	
Copy Speed (A4, Black): Up to	31 cpm
Copy Speed (A4, Colour): Up to	31 cpm
Scanning	
ADF Scan	RADF (reversing Duplex)
Scanning Resolution	600 x 600 dpi
Reduce / Enlarge Range	25 - 400%
Faxing	
Modem Speed	33.6 Kbps
Paper Handling	
Paper Handling Standard	150-Sheet Input Tray, 250-Sheet Output Bin, Integrated Duplex, 250-Sheet Input Tray, 50-Sheet Multipurpose Feeder
Paper Handling Optional	550-Sheet Drawer
Paper Input Capacity, Standard: Up to	450 pages 75 gsm bond
Paper Input Capacity, Maximum: Up to	2100 pages 75 gsm bond
ADF Paper Input Capacity: Up to	100 pages 75 gsm bond
Media Types Supported	Card Stock, Envelopes, Labels, Plain Paper, Transparencies, Refer to the Card Stock & Label Guide, Banner Paper
General	
Function	Colour Copying, Colour Faxing, Colour Printing, Colour Scanning, Colour Network Scanning
Product Guarantee	1-Year Onsite Service, Next Business Day
Product Certifications	www.lexmark.co.uk
Size (mm - H x W x D)	771 x 672 x 668 mm
Weight (kg)	79.3 kg
Specified Operating Environment	Temperature: 10 to 32°C (50 to 90°F), Humidity: 20 to 80% Relative Humidity, Altitude: 0 - 2300 Meters (7,545 Feet)

#### Recommended Monthly Page Volume

\*Recommended Monthly Page Volume\* is a range of pages that helps customers evaluate Lexmark's product offerings based on the average number of pages customers plan to print on the device each month. Lexmark recommends that the number of pages per month be within the stated range for optimum device performance, based on factors including: supplies replacement intervals, paper loading intervals, speed, and typical customer usage.

#### Maximum Monthly Duty Cycle

\*Maximum Monthly Duty Cycle\* is defined as the maximum number of pages a device could deliver in a month using a multishift operation. This metric provides a comparison of robustness in relation to other Lexmark printers and MFPs.

#### Trademarks

Lexmark and Lexmark with the diamond design are trademarks of Lexmark International, Inc., registered in the United States and/or other countries. All other trademarks are the property of their respective owners. ENERGY STAR® is a U.S. registered mark. Information in this document is subject to change without notice. PANTONE® is a registered trademark of Pantone, Inc. This product features Adobe® Flash® technology. For further information, visit <http://www.adobe.com/software/flash/about/> AirPrint and the AirPrint logo are trademarks of Apple Inc.

Print Less. Save More.

[www.lexmark.co.uk](http://www.lexmark.co.uk)



**LEXMARK**  
TM