

Lexmark CX410 Series Multifunction Colour Laser Printer

Stunning Colour. Stellar Versatility.

The Lexmark CX410 Series MFP colour laser desktop printer does more than deliver PANTONE® colour matching and fast print, fax, copy and scan speeds, it offers optional solutions to help streamline your business. *Want to do two-sided printing capabilities? Choose the CX410de. Need more capacity? Get the CX410dte.*



Colour



Up to 30
ppm



10.9-cm (4.3-
inch) Touch
Screen



Solutions



Fax

Unison™
TONER



CX410e/de

Accurate Colour That's Brand-Worthy.

The Lexmark CX410 Series MFP delivers rich, consistent colour printing that can enhance your company's materials and brand. It's faster and more reliable than ever.

Freedom to Print on the Fly - Produce professional colour in-house, on demand. With 512 MB of upgradable memory and a fast dual-core processor, you'll have speed as well as power and convenience.

Professional Colour Matching - Lexmark Named Color Replacement and PANTONE® calibration make it easy to develop a consistent brand image by accurately matching your colours.

High Resolution Graphics - With up to true 1200x1200 dpi resolution, images and graphics stay crisp. Lexmark's Unison™ Toner ensures consistent quality, too.

Super Fast and Quiet Output - Quickly print, copy and scan up to 30 pages per minute in black and colour, plus produce a one-page colour document in as little as 11.5 seconds.

More Productivity. Less Hassle.

Produce everything on the spot, from in-store signage to customer presentations. Features, like an easy-to-read user control panel, large output bin and more, make printing a breeze.

Reliable Performance - Easily print up to 6,000 pages a month, plus enjoy fewer maintenance hassles, thanks to state-of-the-art paper handling.

Run Larger Jobs without Interruption - With an input capacity of up to 1,450 sheets and high yield toner cartridge options, you won't have to add paper or change cartridges as often.

Easy-to-Read Colour Touch Screen - Stay on top of your jobs with our convenient 10.9-cm (4.3-inch) colour touch screen and front direct USB port.

Innovative Toner That Optimises Performance - Get greater system performance with Lexmark's Unison™ Toner, which delivers consistent image quality from first print to last.

Productive Workflows. Sustainable Design.

Quickly respond to changing business needs with our eco-friendly printers that streamline your workflow.

Help Workers Do More - With standard Gigabit Ethernet networking, our system can print jobs from the network faster, so your team stays productive.

Enjoy Enterprise-level Security - Now you can authenticate, authorise and audit employee usage. Plus, protect sensitive data using standard network security protocols.

Save Resources and the Planet - An instant warm-up fuser, built-in two-sided printing⁸, plus Quiet, Hibernate and Eco modes minimise noise and save paper and energy.

Print Anytime and Anywhere⁶ - With this system, you can print from desktops as well as mobile devices that can run applications.

LEXMARK
™

Lexmark CX410 Series Multifunction Colour Laser Printer

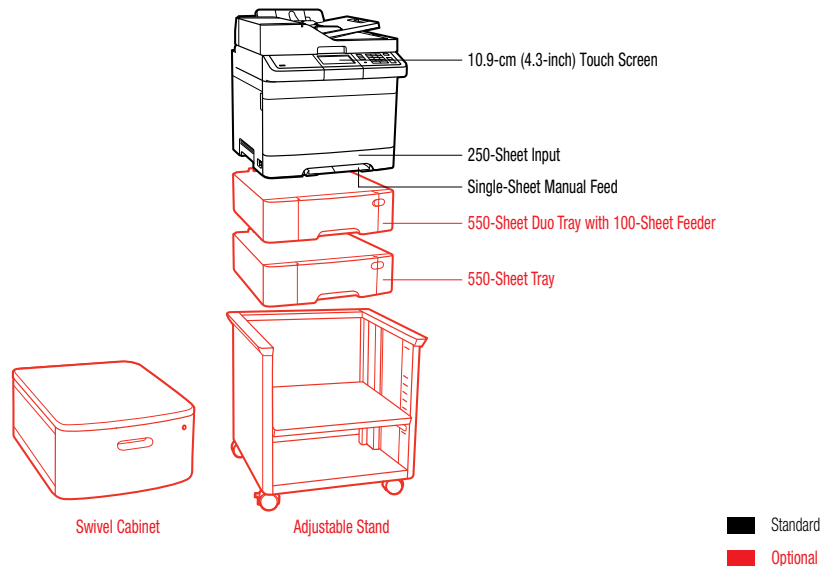

Product specifications	Lexmark CX410e	Lexmark CX410de	Lexmark CX410dte
Printing			
Function	Colour Copying, Colour Faxing, Colour Printing, Colour Scanning		
Display	Lexmark e-Task 10.9 cm (4.3-inch) colour touch screen		
Print Speed: Up to ¹	Black: 30 ppm / Colour: 30 ppm		
Time to First Page: As fast as	Black: 10.5 seconds / Colour: 11.5 seconds		
Print Resolution	Black: 1200 x 1200 dpi, 4800 Colour Quality (2400 x 600 dpi) / Colour: 1200 x 1200 dpi, 4800 Colour Quality (2400 x 600 dpi)		
Memory / Processor	Standard: 512 MB / Maximum: 2560 MB / Processor: Dual Core, 800 MHz		
Hard Disk	Not Available		
Recommended Monthly Page Volume ²	800 - 6000 pages		
Maximum Monthly Duty Cycle: Up to ³	75000 pages per month		
Copying			
Copy Speed: Up to ⁴	Black: 30 cpm / Colour: 30 cpm		
Time to First Copy: As fast as	Black: 10.8 seconds / Colour: 11.6 seconds		
Colour Scanning			
Scanner Type / ADF Scan	Flatbed scanner with ADF / RADF (reversing Duplex) / 50 pages 75 gsm bond		
Duplex Scan Speed: Up to	A4/Ltr, Black: 13 / 14 sides per minute - A4/Ltr, Colour: 13 / 14 sides per minute		
Simplex Scan Speed: Up to	A4/Ltr, Black: 30 / 32 sides per minute - A4/Ltr, Colour: 30 / 32 sides per minute		
Optical Scanning Resolution	600 X 600 ppi (colour), 1200 X 600 ppi (black)		
Faxing			
Modem Speed	ITU T.30, V.34 Half-Duplex, 33.6 Kbps		
Supplies⁵			
Laser Cartridge Yields	1,000 ¹ -page Black and Colour (CMYK) Cartridges, 2,000 ¹ -page Colour (CMY) Cartridges, 2,500 ¹ -page Black Cartridge, 3,000 ¹ -page Colour (CMY) High Yield Cartridges, 4,000 ¹ -page Black High Yield Cartridge		
Cartridge(s) Shipping with Product	1,400 ¹ -page Black and Colour (CMYK) Starter Return Program Toner Cartridges		
Paper Handling			
Included Paper Handling	250-Sheet Input, 150-Sheet Output Bin, Single-Sheet Manual Feed	250-Sheet Input, 150-Sheet Output Bin, Integrated Duplex, Single-Sheet Manual Feed	250-Sheet Input, 550-Sheet Duo Tray with 100-Sheet Feeder, 150-Sheet Output Bin, Integrated Duplex, Single-Sheet Manual Feed
Optional Paper Handling	550-Sheet Tray, 550-Sheet Duo Tray with 100-Sheet Feeder	550-Sheet Tray, 550-Sheet Duo Tray with 100-Sheet Feeder	550-Sheet Tray
Paper Input Capacity: Up to	Standard: 250+1 pages 75 gsm bond / Maximum: 1450+1 pages 75 gsm bond	Standard: 250+1 pages 75 gsm bond / Maximum: 1450+1 pages 75 gsm bond	Standard: 900+1 pages 75 gsm bond / Maximum: 1450+1 pages 75 gsm bond
Paper Output Capacity: Up to	Standard: 150 pages 75 gsm bond / Maximum: 150 pages 75 gsm bond		
Media Types Supported	Card Stock, Paper Labels, Plain Paper, Transparencies, Refer to the Card Stock & Label Guide	Card Stock, Paper Labels, Plain Paper, Transparencies, Refer to the Card Stock & Label Guide	Card Stock, Envelopes, Paper Labels, Plain Paper, Transparencies, Refer to the Card Stock & Label Guide
Media Sizes Supported	A4, A5, Executive, Folio, JIS-B5, Legal, Letter, Universal, Oficio	A4, A5, Executive, Folio, JIS-B5, Legal, Letter, Universal, Oficio	10 Envelope, 7 3/4 Envelope, 9 Envelope, A4, A5, B5 Envelope, C5 Envelope, DL Envelope, Executive, Folio, JIS-B5, Legal, Letter, Statement, Universal, Oficio, A6
General⁷			
Connectivity (standard)	USB 2.0 Specification Hi-Speed Certified (Type B), Gigabit Ethernet (10/100/1000), Front USB 2.0 Specification Hi-Speed Certified port (Type A)		
Optional Network Ports / Optional Local Ports	MarkNet N8352 802.11b/g/n Wireless		
Noise Level, Operating	Print: 50 dBA / Copy: 50 dBA / Scan: 50 dBA		
Product Guarantee	1-Year Onsite Service		
Size (mm. - H x W x D) / Weight (kg)	470 x 444 x 558 mm / 27.39 kg	470 x 444 x 558 mm / 27.39 kg	600.3 x 444 x 589 mm / 31.6 kg

¹ Average continuous black or continuous composite CMY declared cartridge yield up to this number of standard pages in accordance with ISO/IEC 19798. ² "Recommended Monthly Page Volume" is a range of pages that helps customers evaluate Lexmark's product offerings based on the average number of pages customers plan to print on the device each month. Lexmark recommends that the number of pages per month be within the stated range for optimum device performance, based on factors including: supplies replacement intervals, paper loading intervals, speed, and typical customer usage. ³ "Maximum Monthly Duty Cycle" is defined as the maximum number of pages a device could deliver in a month using a multishift operation. This metric provides a comparison of robustness in relation to other Lexmark printers and MFPs. ⁴ Print and copy speeds measured in accordance with ISO/IEC 24734, excludes first set of test documents. For more information see: www.lexmark.com/ISOspeeds. ⁵ Product functions only with replacement cartridges designed for use in a specific geographical region. See www.lexmark.com/regions for more details. ⁶ For more information on Lexmark Mobile Solutions see: http://www1.lexmark.com/en_US/solutions/business-solutions/mobile-print/index.shtml ⁷ Printers are sold subject to certain license/agreement conditions. See www.lexmark.com/printerlicense for details. ⁸ Duplex (two-sided printing) models are ENERGY STAR compliant, CX410de/dte only.

